



CM2 UPGRADE INSTRUCTIONS



MOTOR ASSEMBLY REMOVAL

1. Disconnect the **RED (+)** and **BLACK (-)** wires from battery source.

NOTE: For motors like the one in **FIG A**, remove the **RED (+)** and **BLACK (-)** wires from Reversing Relay to battery source. Then, remove Reversing Relay, Dash Switch, Wiring Harness, Remote Receiver Box, and any other wired controls.

2. Using a Phillips-Head Screwdriver, unscrew the (4) **Phillips-Head Bolts** that attach the **Pump Cap** to the **Motor Assembly**. **FIG 1**

NOTE: Cap may look like the one in **FIG A**.



Figure A



Figure B

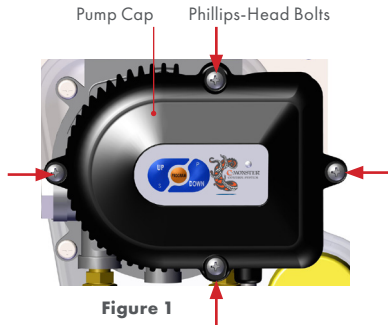

Figure 1

MOTOR ASSEMBLY REMOVAL

3. Unscrew the (2) **Phillips-Head Bolts** that hold the **Motor Assembly** to the **Pump Housing**. **FIG 2**

NOTE: For motors like the one in **FIG B**, use an 8mm socket or wrench.

4. Lift the **Motor Assembly** and **Rubber O-Ring** off of the **Pump Housing**. **FIG 3**

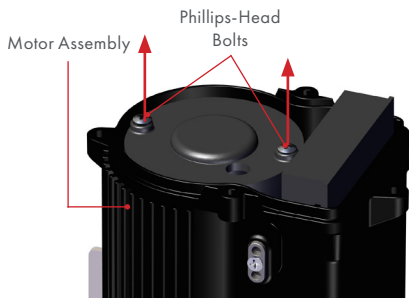

Figure 2

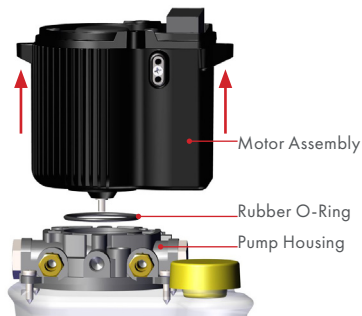

Figure 3

CM2 MOTOR ASSEMBLY INSTALLATION

1. Remove the **Pump Cap** by pulling on the **Tab** and lifting up on the **Cap**. **FIG 1**
2. Remove the **Membrane**. **FIG 2**
3. Using the **Pump Cap**, pry the front of the **Circuit Board** up and remove it. **FIG 3**

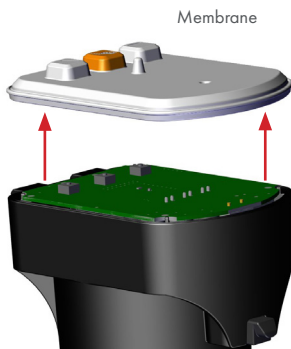

Figure 2



Figure 3a

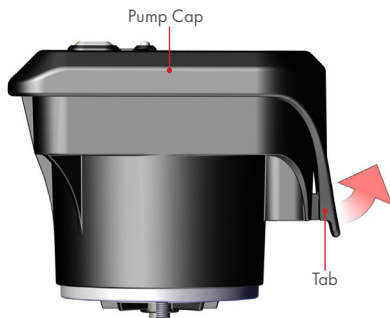

Figure 1

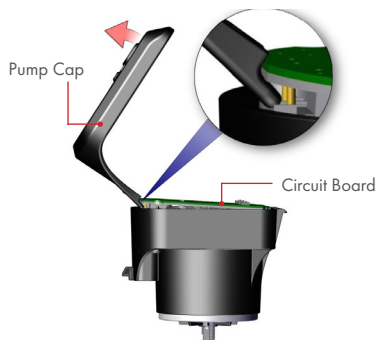

Figure 3

IMPORTANT: DO NOT touch **Antenna**. **FIG 3a**

CM2 MOTOR ASSEMBLY INSTALLATION

4. Remove the (2) **Nuts** from the **Motor Bolts** using a **3/8" wrench**. DO NOT remove the **Rubber Gasket**.
FIG 4
5. Position the new **Motor Assembly** on top of the **Pump Housing**, making sure the **Motor Shaft** lines up with the **Coupler Slot**. **FIG 5 & 6**

IMPORTANT: Add **Marine Grease** to area around **Coupler Slot** if needed.

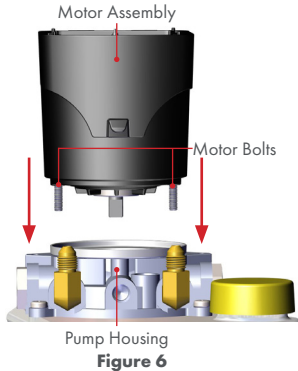
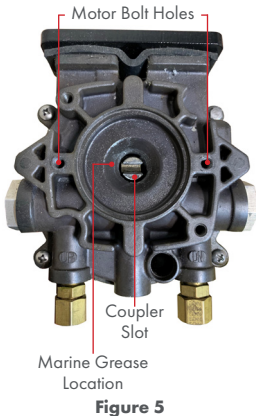
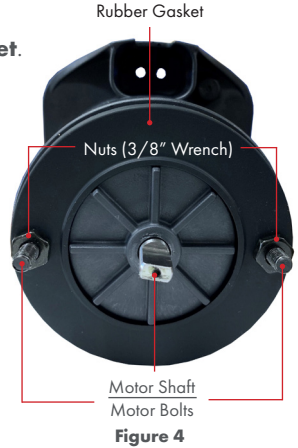

CM2 MOTOR ASSEMBLY INSTALLATION

6. Tighten the (2) **Motor Bolts** snug using a Phillips-Head Screwdriver. **FIG 7a**

7. Install the **Circuit Board**. **FIG 7**

IMPORTANT: Make sure the **Desi Pak** is on top of the **Motor Assembly**. **FIG 7a**

8. Install the **Membrane**. Make sure it seats squarely in the **Motor Casing Groove**. **FIG 8**

9. Reinstall the **Pump Cap**. You may need to push up on the **Wire Harness** while pushing down on the **Cap**. **FIG. 9**

NOTE: If buttons stick, remove the **Pump Cap** and reinstall the **Membrane**.

10. Connect the **RED (+)** and **BLACK (-)** wires to the battery source.

Once both wires are securely fastened, **LED** on top of motor unit will flash **GREEN**, indicating the unit has power.

CM2 Upgrades come factory set as a single unit. For dual configurations, pumps must be programmed as either a "**Port**" or "**Starboard**" unit. Follow the instructions below:

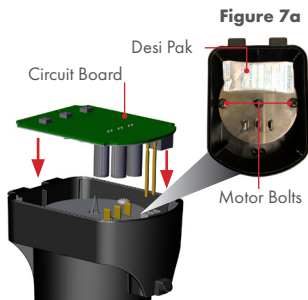

Figure 7

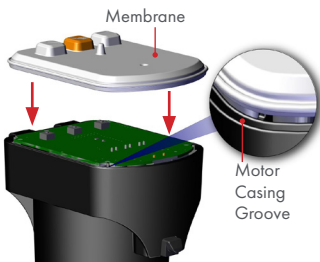

Figure 8

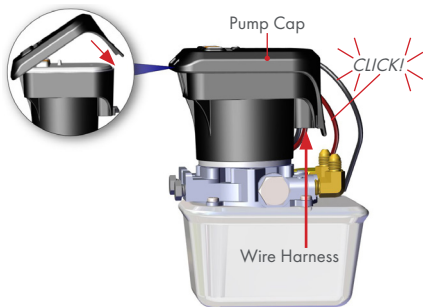

Figure 9

PROGRAMMING HPU

Press and hold the **PROGRAM** button for 6 seconds until the **LED** flashes **RED** and 2 chimes are heard followed by a single beep.

- **Starboard HPU:** Press and release the **UP** Button. **LED** will flash **RED** 1 time with a single beep. Press and release the **PROGRAM** button to save and exit. **LED** will flash **RED** 1 time with a single beep followed by 2 consecutive beeps.
- **Port HPU:** Press and release the **DOWN** button. **LED** will flash **RED** twice with 2 consecutive beeps. Press and release the **PROGRAM** button to save and exit. **LED** will flash **RED** 2 times with a double beep followed by 2 consecutive beeps.
- Programming may also be done via the C-Monster App.



IMPORTANT: When Programming a new Motor Unit, connect it to the C-Monster app to check for a firmware update!

REMOTE PAIRING

New remotes will need to be paired to the upgraded CM2 pumps. Either follow the instructions included with the remote you wish to pair, or scan the QR code for the remote type you wish to pair.



Pairing Power-Pole
Anchor Remotes

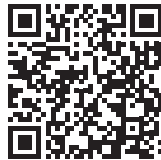

Pairing to Power-Pole
Hybrid Remotes

Need Help? Contact our Customer Service Team at
1 + 813.689.9932



9010 Palm River Road Tampa, Florida 33619
Phone 1+ (813) 689-9932 | Fax 1+(813) 689-8883
www.power-pole.com

Need help? Contact our Customer Service Team at **1 + 813.689.9932 Option 2**



©2026 All rights reserved. Power-Pole Shallow Water Anchor