

POWER-POLE®

Blade®

POWERED BY

ONE™
DUAL ANCHOR PUMP

**SHALLOW WATER ANCHOR
INSTALLATION & OWNER'S GUIDE**

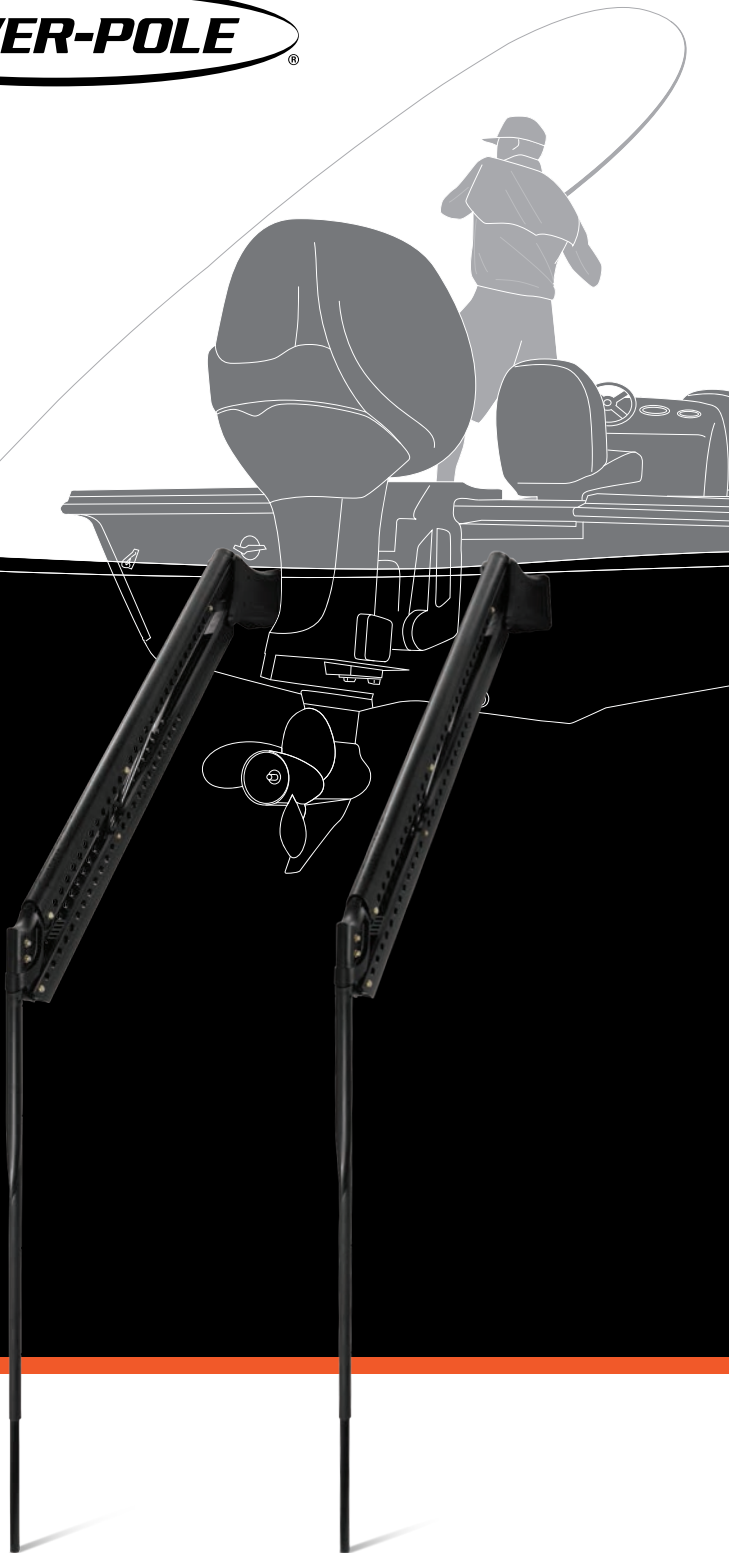

Powered by



C-MONSTER®
CONTROL SYSTEM 2.0



POWER-POLE
ONE
DUAL ANCHOR PUMP

Blade 8



TABLE OF CONTENTS

INSTALLATION	4
Parts List.....	4
Choosing a Mounting Location.....	6
Mounting the Anchors.....	6
Installing the HPU.....	7
Installing the Hydraulic Hoses.....	9
Priming the HPU.....	11
Installing the Remote Cradle.....	12
OPERATION	13
One Pump Remote.....	13
One Pump Remote Battery Replacement.....	13
Bypass Valve Pressure Relief Procedure.....	14
MAINTENANCE AND STORAGE	15
PRECAUTIONS	16
FAQ's	17
WARRANTY INFORMATION	18



Congratulations on your purchase of a Power-Pole® ONE™ Pump, dual anchor system.

The ONE™ Pump has been designed, engineered, and manufactured to provide the best possible performance and dependability. Please read all installation instructions carefully.

The information contained here describes the proper procedures for safely installing your Power-Pole shallow water anchor. If you have questions, contact our Customer Service Team at **1+ (813) 689-9932 option 2** or visit our website at **www.power-pole.com**.



INSTALLATION

INSTALLATION HARDWARE

LABEL	DESCRIPTION	QTY.
SHROUD KIT (SB-SHRD-KIT-XX)		
A	Left Shroud	2
B	Right Shroud	2
C	Shroud Screw	16
PUMP HARDWARE KIT (Pump-1P-X-BLS)		
D	1 Quart Green Marine® Biodegradable Hydraulic Fluid	2
E	#10 x 3/4" Flat Head Screw	4
F	10-12 AWG Ring Terminal Connector	2
G	Bulkhead Plate on hydraulic hoses	2
H	#8 - 3/4" Screw	8
I	One Pump Remote	2
J	One Pump Remote Cradle	1
K	#8 1/2" Screw	2
L	Lanyard	1

INSTALLATION TOOLS

- 5/8", 1/2", 7/16" wrenches
- Drill
- 5/16", 5/32", 9/64", 7/64" drill bits
- 3/4" Hole Saw
- #2 Phillips-head bit or screwdriver
- Heat gun
- Fine point marker
- Wire cutters
- Wire terminal crimper
- Small funnel



Do not use the Power-Pole shallow water anchor as your primary anchor. Never leave your boat unattended while anchored solely with the Power-Pole shallow water anchor.

INSTALLATION TOOLS AND HARDWARE

INSTALLATION HARDWARE



Mounting Options

Adapter Plate Mounting

Follow the instructions included with your Power-Pole Adapter Plate. If you do not have an adapter plate, please contact one of our authorized dealers or visit www.power-pole.com and click on "Accessories > Find My Adapter Plate".

For customer service call **1+ (813) 689-9932 option 2.**

Transom Mounting

Follow the instructions included with your Transom Mounting Hardware Kit. If you do not have a hardware kit, please contact our customer service team at **1+ (813) 689-9932 option 2.**

STEP 1 Install Side Shrouds

After installing the Power-Pole to either the transom or an Adapter Plate, install the shrouds **A** and **B**. Then install the (8) screws **C**, ensuring you do not over-tighten. FIG. 1

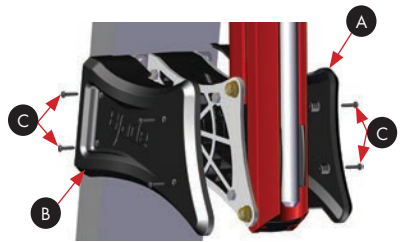
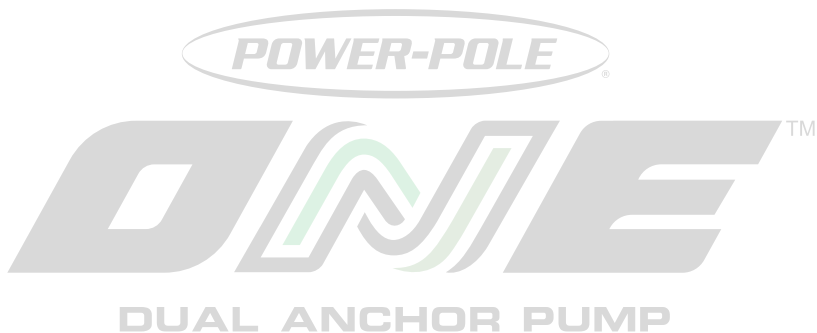

Figure 3



STEP 2 Installing The Hydraulic Pump Unit (HPU)

INSTALLING MOUNTING BRACKET

IMPORTANT: Be sure to follow the **Gel Coat Drilling Procedure** on p.12. Failure to follow this procedure may result in chipping or cracking of your boat's gel coat.

1. Locate a dry compartment in the vessel with space to accommodate the HPU that allows accessibility to remove the quick release pin after the unit is installed. The unit can be mounted to either the floor or wall.

IMPORTANT: The HPU must be mounted in a compartment that is at least **11" tall and 9" in width** in order to install and remove it from the mounting bracket and operate the Quick Release Pin. **FIG. 4 & 7**

2. Remove the fill cap on the HPU and fill the reservoir to the "MAX" line with the supplied two quarts of Green Marine® biodegradable hydraulic fluid **D**.

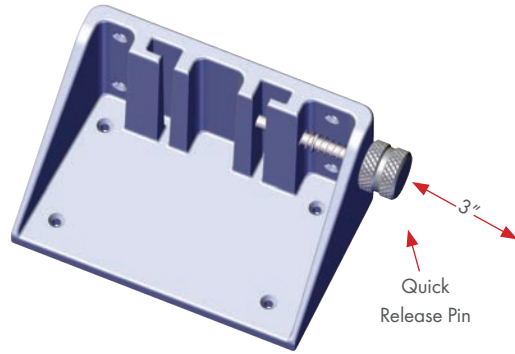

Figure 4
Mounting Holes



Using anything other than an ISO 32 hydraulic fluid such as Green Marine may cause damage to the HPU.

IMPORTANT: The Mounting Bracket can be installed to either the wall or floor. However, all 4 screws **E** must be installed to either the vertical or horizontal mounting surface as shown in **figures 5 & 6**.



Before installing self tapping screws **E**, inspect the area beneath the mounting surface to ensure the screws will not cause any damage.

3. Place the mounting bracket in the ideal location. Using a 5/32" drill bit, drill a pilot hole for one of the screws **E**. Install one screw **E** and tighten snug to hold the bracket in place. **FIG. 4**
4. Check to make sure the bracket has not shifted. Drill pilot holes and install the remaining (3) screws **E**.



Figure 5
Floor Mount



Figure 6
Wall Mount

STEP 3 Installing The Hydraulic Pump Unit (HPU)

INSTALLING HPU AND RESERVOIR

5. Remove the Quick-Release Pin from the bracket by rotating counter-clockwise and pulling it back. Install the reservoir by sliding the tongues on the reservoir into the grooves on the bracket. **FIG. 7**
6. Reinstall the Quick-Release Pin and turn clockwise until tightened snug. **FIG. 7**



DO NOT over-tighten the Quick-Release Pin.

7. Route the red wire to a 12 Volt positive source via a battery switch to prevent power draw when not in use.
8. Route the black wire to the 12 Volt negative common ground post.
9. Install the (2) ring terminal connectors **F** using wire strippers and wire terminal crimper.
10. Heat the (2) ring terminal connectors **F** with a heat gun until their respective jackets shrink completely and adhere to the wires.

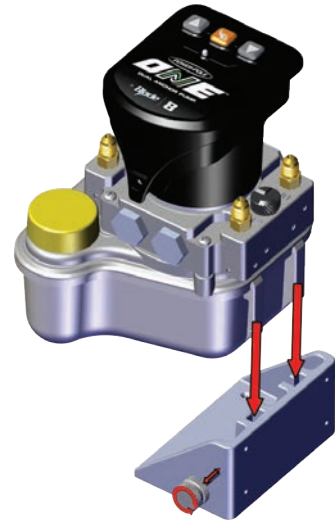
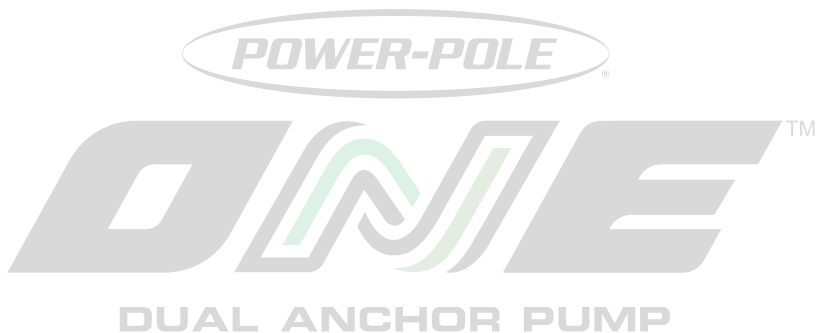

Figure 7



DO NOT CONNECT the red or black wires to the battery at this time. These wires will be connected once the hydraulic hoses are installed.



STEP 4 Installing The Hydraulic Hoses

ROUTING HOSES USING BULKHEAD PLATE



Keep debris out of the hydraulic hose. Do not remove blue/red plastic from the end of hydraulic hose while routing throughout the boat. Debris in the hose will cause damage to the HPU.

IMPORTANT: Be sure to allow an adequate amount of slack in the hydraulic hose between the stern bracket and the point that the hose enters the vessel. This will provide for full up and down operation.

IMPORTANT: Be sure to follow the **Gel Coat Drilling Procedure** on p. 12. Failure to follow this procedure may result in chipping or cracking of your boat's gel coat.

1. Use Template to mark four holes for screws **H** and two holes for the hydraulic hoses.
2. Drill holes for hydraulic hoses using a 3/4" Hole saw.
3. Drill pilot holes for screws **H** with a 7/64" drill bit.
4. Apply a marine grade sealant around the pilot holes.
5. Install screws **H** and bulkhead plate **H**, tightening snug with a #2 Phillips Head screwdriver. **FIG. 9**

IMPORTANT: Put a small amount of marine sealant around grommets before installing into the bulkhead plate **H**.

6. Route hydraulic hoses to HPU through bulkhead plate **H** holes and install thru-hull grommets. **FIG. 9-10**
7. Remove the blue and black dust caps from the hydraulic fittings on the HPU, connect each Hydraulic Hose to their respective fittings on the HPU and finger tighten. The hoses from one anchor will connect to the fittings labeled UP1/DN1 and the hoses from the other will connect to the fittings labeled UP2/DN2. **FIG. 11**
8. While holding the base fitting with a 7/16" wrench, tighten an additional 1/4 turn using a 5/8" Wrench. **FIG. 11**

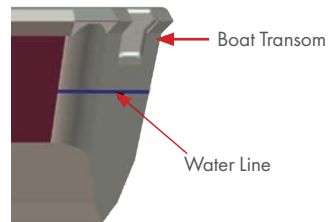

Figure 8

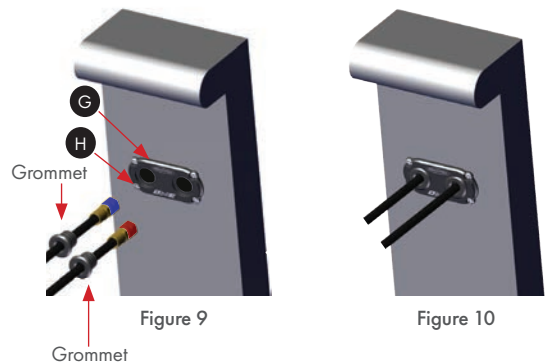

Figure 9

Figure 10

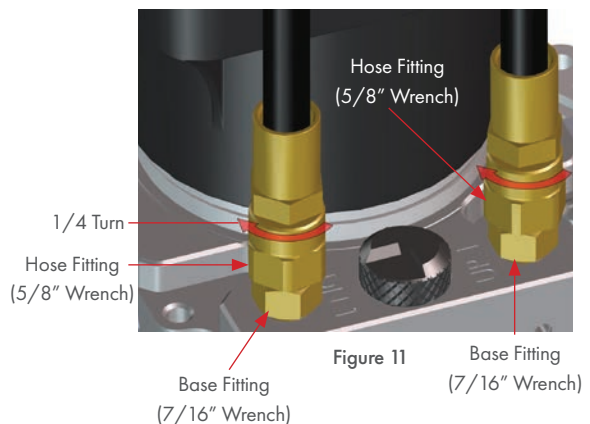

Figure 11

STEP 5 Installing The Hydraulic Hoses

ROUTING HOSES WITHOUT BULKHEAD PLATE



Keep debris out of the hydraulic hose. Do not remove blue/red plastic from the end of hydraulic hose while routing throughout the boat. Debris in the hose will cause damage to the HPU.

1. The hydraulic hose may be routed either over the transom or through the transom. **FIG 12-13**. If the hydraulic hose is not being installed through the transom, route the hose to the HPU and proceed to **Step 3** below.

IMPORTANT: Be sure to allow an adequate amount of slack in the hydraulic hose between the stern bracket and the point that the hose enters the vessel. This will provide for full up and down operation.

IMPORTANT: Put a small amount of marine sealant around grommets before installing into the boat transom.

NOTE: Thru-hull grommets may be removed from hydraulic hoses if not being used.

IMPORTANT: Be sure to follow the **Gel Coat Drilling Procedure** on p. 12. Failure to follow this procedure may result in chipping or cracking of your boat's gel coat.

2. For each Power-Pole anchor, mark two 3/4" holes on the transom above the water line for grommets spaced 1-1/4" apart. Then, drill a pilot hole in the middle of each marked hole with a 5/16" drill bit. Next, drill pilot holes out with a 3/4" hole saw, route hydraulic hoses to HPU through transom holes and install thru-hull grommets. **FIG. 14-15**

3. Remove the blue and black dust caps from the hydraulic fittings on the HPU.
4. Connect each Hydraulic Hose to their respective fittings on the HPU and finger tighten. The hoses from one anchor will connect to the fittings labeled UP1/DN1 and the hoses from the other will connect to the fittings labeled UP2/DN2.

FIG. 16

5. While holding the base fitting with a 7/16" wrench, tighten an additional 1/4 turn using a 5/8" Wrench. **FIG. 16**

OVER TRANSOM

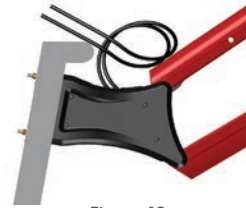

Figure 12

THROUGH TRANSOM



Figure 13

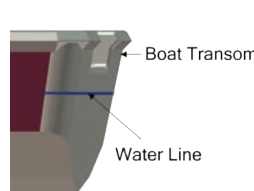

Figure 14

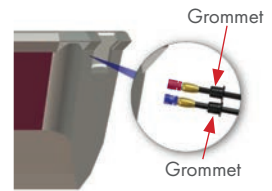

Figure 15

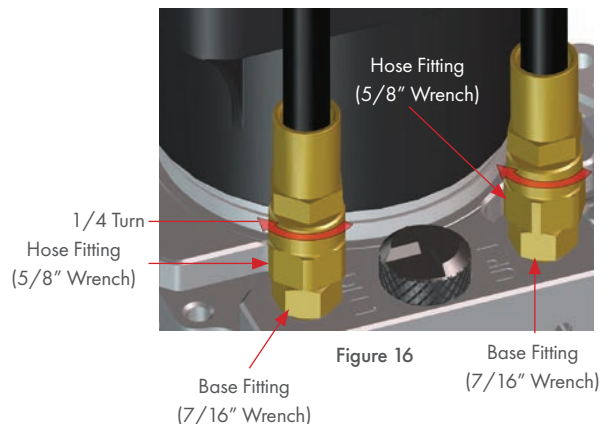

Figure 16

STEP 6 Priming The HPU

IMPORTANT! Before priming, be sure that each pressure relief valve is fully tightened down. See **Pressure Relief Valve** p. 14 for more information.

1. Connect the red fuse holder ring terminal to the main battery cut-off switch and the black ring terminal to negative common ground post. The HPU will make a charge audio ID tune and the LED indicator light will begin flashing **GREEN**. **FIG. 17**
2. Manually, lower the anchor to the deployed position.
3. Using the One Pump Remote, change to the slowest speed. See Operation section (p.13) to change speed settings.
4. Hold the Down button until the **GREEN** LED on the dash remote stops flashing and the pump stops running. (Approximately 20 sec.) Repeat twice.

NOTE: The HPU will have a high pitch whining sound while priming until the air has dissipated from hydraulic fluid.

5. Check the fluid level in the reservoir and add if necessary.
6. Hold the UP button until the **GREEN** LED on the One Pump Remote stops flashing and the pump stops running. (Approximately 20 sec.) Repeat this process two more times or until the Power-Pole anchors are fully retracted.
7. Repeat steps 4 & 6 once.
8. Change the One Pump Remote to medium speed setting.
9. Repeat steps 4 & 6 once.
10. With the anchors in the stowed position, push on the anchors to test the prime. If the anchors do not stay fully retracted when manually forced to deploy, then repeat the priming steps.
11. Once on the water, navigate to water deep enough to fully deploy the anchors without touching the bottom and retract the anchors six times to finish the priming process.
12. Your Power-Pole anchors should be completely primed at this point, but if you suspect it isn't, repeat step 11 until it is or contact JL Marine System's Inc. for **Customer Service at 813-689-9932 Option 2**.



Figure 17

STEP 7 Installing The Remote Cradle

NOTE: The remote cradle **J** may also be installed using the supplied adhesive strip.

IMPORTANT: Be sure to follow the **Gel Coat Drilling Procedure** below. Failure to follow this procedure may result in chipping or cracking of your boat's gel coat.

1. Locate a suitable area with a flat surface to mount the remote cradle **J**.
2. Mark the upper hole location with a fine point marker and drill a pilot hole using a 7/64" drill bit.
3. Place the remote cradle **J** in the desired location and install one of the screws **H** through the top hole in the remote cradle **J**.
4. Repeat Steps 2-3 for the lower hole and mounting screw **H**.



Figure 18



Before installing the self tapping screws, inspect the area beneath the mounting surface to ensure that the screws will not cause any damage.

GEL COAT Drilling Procedure



Always follow this procedure when drilling into the gel-coat of a boat. Failure to follow this procedure may result in chipping or cracking of your boat's gel-coat.

1. Cover the area that will be drilled with blue painter's tape.
2. Mark holes on masking tape with a fine-tip marker.
3. Drill a pilot hole with a drill bit that is 1/8" or less. Then, drill the hole again using a drill bit that is 1/16" larger. Repeat this process, increasing drill bit size by 1/16" until holes are the desired diameter.

OPERATION

Here you'll find information on all of the functions, safe use, and proper maintenance of your shallow water anchor. If you have questions, contact our Customer Service Team at **1 + (813) 689-9932 option 2** or visit our website at **www.power-pole.com**.

One Pump Remote

Your Power-Pole Anchor comes with (2) One Pump Remotes. These remotes can be used to operate the anchors and control the speed at which the anchors are stowed or deployed.

DEPLOYMENT OPTIONS

To raise or lower your Power-Pole anchors, press and hold either the UP or DOWN button. The anchor will only continue to move as long as the button is pressed.

AUTO MODE

Double tapping (pressing and releasing 2 times within 1 second) either the UP or the DOWN button on the remote will retract or deploy the anchors automatically. The anchors will continue to move in said direction until it either retracts completely (Auto Up) or senses a solid bottom surface (Auto Down).

NOTE: Auto mode can be changed to a single tap via the Power-Pole App.

SPEED CONTROL

The remote has 3 speed settings (slow, medium, and fast). Pressing and releasing the Speed Control button will toggle through the 3 settings. The LED lights will flash at a speed that corresponds to either a slow, medium, or fast setting (one flashing light = slowest speed setting, 3 flashing lights = fastest speed setting).



One Pump Remote

ONE PUMP REMOTE BATTERY REPLACEMENT

IMPORTANT! Ensure the switch and the surrounding area is as dry as possible to avoid any moisture intrusion before changing the battery in the controller.

STEP 1 Insert a small flathead screwdriver into the bottom of the remote to pry it apart.

STEP 2 Remove the battery from the holder on the circuit board and replace with a CR2032 3V lithium coin battery.

STEP 3 Re-assemble the remote, ensuring that the membrane is seated properly in the front shell prior to installing the cover and the front and rear shells fully snap into place.



BYPASS VALVE Procedure



Hydraulic lines are always pressurized and disconnecting them will cause a sudden high pressure release. This high pressure release may cause oil leakage from the lines and/or fittings. When depressurizing the lines, the unit must be supported otherwise the anchor will fall to the fully deployed position. This may result in damage to the unit as well as bodily harm.

All Power-Pole One Pump HPU's come with bypass valves for each Power-Pole. In the event that you are unable to stow your anchor or you wish to relieve pressure to service the hydraulic system, follow this procedure to safely and easily relieve pressure from the hydraulic system.

IMPORTANT! The Bypass valve is intended to be operated by hand or with a flathead screwdriver. The use of pliers or other tools can cause damage to the valve and other sensitive components.

STEP 1 If servicing the hydraulic system, ensure the anchors are deployed.

STEP 2 Locate the **bypass valves** on either side of the HPU. Each anchor has its own pressure relief valve. **FIG. 1**

STEP 3 Press down on and slightly rotate the **bypass valve** a 1/4 turn counter-clockwise, relieving pressure. **FIG. 2**

IMPORTANT! Only rotate 1/4 turn. Over-rotating or excessive force may cause irreparable damage to the hydraulic system.

NOTE: Once pressure is relieved, the valve will pop up indicating you are able to manually retract or service the anchor.

FIG. 3



To ensure the anchor does not fall down, secure the anchor in the retracted position with a rope or tie-down strap.

STEP 4 Begin servicing the anchor. If needed, push the anchor back into a closed position.

STEP 5 After anchor service is completed, or the anchor has been manually retracted, push the **bypass valve** back down and rotate it clockwise 1/4 turn so it is locked back in the engaged position.

IMPORTANT! Only rotate 1/4 turn. Over-rotating or excessive force may cause irreparable damage to the hydraulic system.

STEP 6 If possible, re-run the motor "UP" to pressurize the system and prevent any excessive vibration.



Figure 1

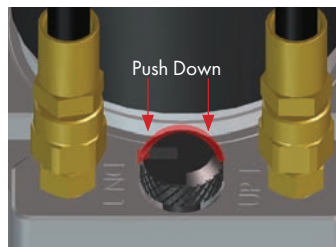

Figure 2

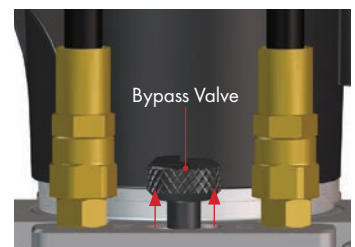

Figure 3

Power-Pole App



DOWNLOAD the Power-Pole App for a tailored Power-Pole experience, scan the QR codes for the Android and iOS apps.



MAINTENANCE and Storage

- Inspect all hydraulic lines for kinking or abrasion prior to use.
- Inspect all hydraulic fittings for leaks and proper tightness prior to each use.



If disconnecting the hydraulic lines, please read the following: Hydraulic lines are always pressurized and disconnecting them will cause a sudden high pressure release. This high pressure release may cause oil leakage from the lines and/or fittings. When depressurizing the lines the unit must be supported otherwise the anchor will fall to the fully deployed position. This may result in damage to the unit as well as bodily harm.

- Inspect all electrical connections to ensure that they are secure and free of corrosion every 3 months.
- Inspect all fasteners for proper tightness after every 100 cycles to ensure that the Power-Pole anchor is in safe working condition.
- Ensure that the Green Marine® biodegradable hydraulic fluid level is within the indicator marks on the reservoir at all times.
- Thoroughly rinse all moving parts with fresh water after each use.
- Lubricate the bushings at the knuckle hinge points with spray lithium grease every 6 months.



PRECAUTIONS



- Prior to use, read this guide carefully. Become familiar with the controls and how to operate your Power-Pole anchors properly.
- Do not allow children to operate or tamper with the Power-Pole anchors without adult supervision.
- Do not modify the unit in any way.
- Use only genuine Power-Pole anchor accessories.
- Always disconnect the 12 Volt power source from the Power-Pole anchor before servicing.
- In the event of HPU failure, your Power-Pole anchors may be manually stowed by following the **Pressure Relief Valve Procedure**.
- Be sure to have your Power-Pole anchors in the stowed (fully upright) position while operating your vessel at high speeds.
- Always maintain a safe distance between the Power-Pole anchors and your extremities. Avoid wearing loose clothing within close proximity of the anchors; failure to do so may result in bodily injury.
- Do not use your Power-Pole anchors as a form of assistance for entering or exiting the vessel.
- Never leave your boat unattended with the Power-Pole anchors as the primary anchorage.
- During situations with high wind or rough seas, your Power-Pole anchors may release holding pressure in order to protect your vessel's transom.
- If any debris gets caught around your Power-Pole anchors, disconnect the 12 Volt power source prior to removal.
- Always ensure that your Power-Pole anchors are in the stowed position when traveling.



FAQ

Frequently Asked Questions



For Customer Service, please call 1+(813) 689-9932 option 2.

Q: How often should I change my hydraulic fluid?

A: While there is no recommended time interval for a hydraulic fluid flush, the fluid should be changed if there is any visible debris in the reservoir. Additionally, if the fluid appears milky or white it should be changed immediately; white fluid is a sign of water intrusion and the entire system should be checked for leaks.

Q: What type of hydraulic fluid should I use?

A: The HPU reservoir should be filled with Green Marine® biodegradable hydraulic fluid or an ISO 32 hydraulic fluid. Green Marine is available through all authorized Power-Pole dealers.

Q: Why is my Power-Pole Only priming one side?

A: Check to ensure both bypass valves are tightened down. See **Pressure Relief Valve Procedure** p. 14 for more information.

Q: How will the Power-Pole affect my battery during operation?

A: The average life of a 12 Volt battery with 55 cold cranking amps is 2,500 cycles per charge.

Q: Will the C-Monster HPU drain my battery when it is not in use?

A: No. Although the HPU should be powered off via a battery switch when stored, the amperage draw on your vessel's battery is a negligible 38 mA. You may set your Power-Pole HPU to enter Hibernation Mode after a set time of rest via the Power-Pole App. In this mode, the HPU will only draw (20 mA). However, any movement such as when trailering may cause the unit to turn back on.

Q: What should I do if my Power-Pole anchor is stuck in the deployed position?

A: If your Power-Pole anchor will not retract for any reason follow the **Pressure Relief Valve Procedure** instructions and stow your anchor.

Q: How many wireless remotes can I program to my C-Monster System?

A: Up to eight (8) wireless remotes can be programmed to operate Power-Pole anchors.

Q: How do I program a new wireless remote to my existing C-Monster system?

- A:
1. Press and hold the PROGRAM button on top of the (HPU) hydraulic pump unit for 3 seconds until the LED turns solid **GREEN** (HPU will also beep).
 2. Press and hold either the UP or DOWN button on the wireless remote you are pairing until the unit responds.

Q: How do I adjust the speed on the One Pump remote?

A: The included One Pump remote comes out of the box set to 70% of the highest speed level. This can be adjusted by downloading the Power-Pole App and connecting to the system via Bluetooth with your Android powered smart phone or Apple iPhone.

Q: What size fuse does the One Pump use?



A: The One Pump uses a 60A fuse.

Q: What are the dimensions of the One Pump?

A: 6 1/2" x 6 1/2" x 9"

Q: What do the different HPU LED Colors Indicate?

A: The HPU LED will change colors depending on battery voltage.

HPU INDICATOR LIGHT GUIDE	
LIGHT	INDICATION
Flashing GREEN Light 	NORMAL: System has proper voltage (11.9V – 16.4V).
Flashing ORANGE Light 	LOW: System has low voltage (10.8V – 11.8V).
Flashing RED Light 	WARNING: System has low voltage (10.7V or less). NOTE: When voltage is below 6V or above 16.5V the unit will not operate.

LIMITED Warranty



To find a Certified Warranty Center, visit www.power-pole.com.

Five (5) Year Limited Warranty Conditions of this Warranty



A Power-Pole shallow water anchor manufactured by JL Marine systems Inc. is warranted against defects in material and workmanship in the stern bracket, knuckle joint, U-channel, hydraulic system, and electrical system to the original end consumer from the original purchase date according to the following stipulations:

1. Power-Pole shallow water anchor warranties are activated when product is registered online at www.power-pole.com/register or by using the C-Monster smart phone app or upon receipt by JL Marine Systems, Inc. of a completed warranty card, postdated within (10) days of the original purchase date. Please retain your sales receipt as proof of purchase.
2. Install Genuine Power-Pole Merchandise ONLY. This warranty is void if any non authorized parts are used or installed.
3. This warranty is void if the Power-Pole shallow water anchor is used commercially, structurally altered, or subject to stress beyond the physical limits of the manufactured material.
4. This warranty does not cover abrasion or abnormal abuse, nor does it cover the Power-Pole shallow water anchor for anything other than its intended use.
5. JL Marine Systems, Inc. reserves the right to change products and designs without incurring any obligations to incorporate such changes in already completed products, or those in the hands of dealers or consumers. Products repaired or replaced under this warranty may or may not have these changes.

Shipping (Only applies to packages shipped within the Continental U.S.)

1. Parts which prove defective within (90) days from the date of purchase, JL Marine Systems, Inc. will pay for the replacement product shipping and handling fees to and from the JL Marine Systems, Inc. manufacturing plant or some other place which JL Marine Systems, Inc. might designate.
2. Parts which prove defective after (90) days but before (12) months from the date of purchase will also be repaired or replaced free of charge, but there may be a shipping charge to JL Marine Systems, Inc. manufacturing plant or some other place which JL Marine Systems, Inc. might designate.
3. Parts which prove defective after (12) months will also be repaired or replaced free of charge, but there may be a shipping and handling charge to and from the JL Marine Systems, Inc. manufacturing plant or some other place which JL Marine Systems, Inc. might designate.

Parts

1. A **Stern bracket, Knuckle joint or U-channel**, which proves defective before sixty (60) months will be repaired or replaced free of charge. In the case of replacement, parts of same (or equivalent) model will be used.
2. The **Hydraulic Pump Unit (HPU)** which proves defective within (24) months from date of purchase will be repaired or replaced free of charge. Pump damage due to incorrect hydraulic fluid, submersion or excessive exposure to water may void this warranty.
3. The **Powder Coated Finish** is covered for a period of six (6) months not to crack, chip or fade.
4. A **Cylinder, hydraulic hose, Dash Switch or Key-Fob** which proves defective within (24) months from date of purchase will be repaired or replaced free of charge. In the case of replacement, parts of same (or equivalent) model will be used.
5. **Spike unconditional lifetime guarantee.**
6. **This Warranty does not cover water damage in any way.**

THE WARRANTY CONTAINED HEREIN IS THE EXCLUSIVE WARRANTY MADE BY JL Marine Systems, Inc. AND THERE ARE NO OTHER WARRANTIES, EXPRESSED OR IMPLIED, INCLUDING A WARRANTY OF FITNESS FOR A PARTICULAR PURPOSE OR OF MERCHANTABILITY MADE WITH RESPECT TO SUCH ANCHORS. JL Marine Systems, Inc., IS NOT LIABLE FOR ANY INJURY OR MISHAPS SUSTAINED IN THE USE OF THIS PRODUCT. THE USER OF THIS PRODUCT ACKNOWLEDGES ASSUMED RISKS AND WAIVES ANY AND ALL CLAIMS AGAINST JL Marine Systems, Inc. AND ANY OF IT'S AGENTS. This warranty applies under conditions of normal use. The warranty does not cover: 1) defects caused by improper assembly or disassembly; 2) defects occurring after purchase due to product modification, intentional damage, accident, misuse, abuse, negligence or exposure to corrosive elements; 3) cosmetic damage and 4) labor or assembly costs. Except as provided herein, JL Marine Systems, Inc. makes no express warranties, and any implied warranty, including without limitation any implied warranty of merchantability or fitness for a particular purpose, is limited in its duration to the duration of the written limited warranty set forth herein. Except as provided herein, JL Marine Systems, Inc. shall have no liability or responsibility to the purchaser or any other person or entity with respect to any liability, loss or damage caused or alleged to be caused directly or indirectly by use of the product, including, but not limited to, any incidental or consequential damages. Some states do not allow limitation on how long an implied warranty lasts or the exclusion of limitation of incidental or consequential damages, so the above limitation and exclusion may not apply to you. This warranty gives you specific legal rights. You may also have other rights which vary from state to state.



General Statement (for all devices)

Warning: Changes or modifications to this device not expressly approved by JL Marine Systems, Inc. could void the user's authority to operate the equipment.

FCC Specific Statement

NOTE: This equipment has been tested and found to comply with the limits for a Class B digital device, pursuant to Part 15 of the FCC Rules. These limits are designed to provide reasonable protection against harmful interference in a residential installation. This equipment generates, uses, and can radiate radio frequency energy and, if not installed and used in accordance with the instructions, may cause harmful interference to radio communications. However, there is no guarantee that interference will not occur in a particular installation. If this equipment does cause harmful interference to radio or television reception, which can be determined by turning the equipment off and on, the user is encouraged to try to correct the interference by one or more of the following measures:

- Reorient or relocate the receiving antenna.
- Increase the separation between the equipment and receiver
- Connect the equipment into an outlet on a circuit different from that to which the receiver is connected
- Consult the dealer or an experienced radio/TV technician for help

FCC Part 15.19 Warning Statement – (Required for all Part 15 devices) THIS DEVICE COMPLIES WITH PART 15 OF THE FCC RULES. OPERATION IS SUBJECT TO THE FOLLOWING TWO CONDITIONS: (1) THIS DEVICE MAY NOT CAUSE HARMFUL INTERFERENCE, AND (2) THIS DEVICE MUST ACCEPT ANY INTERFERENCE RECEIVED, INCLUDING INTERFERENCE THAT MAY CAUSE UNDESIRE OPERATION.

FCC/ISED RF Exposure

ENGLISH: This equipment complies with radiation exposure limits set forth for an uncontrolled environment. This equipment is in direct contact with the body of the user under normal operating conditions. The transmitter must not be co-located or operating in conjunction with any other antenna or transmitter.

FRENCH: Cet équipement est conforme aux limites d'exposition aux radiations dans un environnement non contrôlé. Cet équipement est en contact direct avec le corps de l'utilisateur dans des conditions de fonctionnement normales. Cet émetteur ne doit pas être co-localisées ou opérant en conjonction avec tout autre antenne ou transmetteur.

ENGLISH: This device complies with Industry Canada license-exempt RSS standard(s). Operation is subject to the following two conditions: (1) this device may not cause interference, and (2) this device must not accept any interference, including interference that may cause undesired operation of the device.

FRENCH: Le présent est conforme aux CNR d'Industrie Canada applicables aux appareils radio exempts de licence. L'exploitation est autorisée aux deux conditions suivantes: (1) l'appareil ne doit pas produire de brouillage, et (2) l'utilisateur de l'appareil doit accepter tout brouillage radioélectrique subi, même si le brouillage est susceptible d'en compromettre le fonctionnement.





CAUTION:

Do not use the Power-Pole shallow water anchor as your primary anchorage.
Never leave your boat unattended while anchored solely with the Power-Pole shallow water anchor.

Need help? Contact our Technical Support Team at

1 + 813.689.9932 option 2



9010 Palm River Road, Tampa, Florida 33619
Phone 1+(813) 689-9932 Fax 1+(813) 689-8883
power-pole.com

SWIFT. SILENT. SECURE.