



SWIFT. SILENT. SECURE.

CM2 CIRCUIT BOARD REPLACEMENT INSTRUCTIONS

REMOVAL:

STEP 1: Disconnect the **RED** 12V (+) wire from the battery source or remove the Inline Fuse.

STEP 2: Remove the **Pump Cap** by pulling on the **Tab** and lifting up on the **Cap**. **FIG 1**

STEP 3: Remove the **Membrane**. **FIG 2**

STEP 4: Using the **Pump Cap**, pry the front of the **Circuit Board** up and remove it. **FIG 3**

IMPORTANT: DO NOT touch **Antenna**. **FIG 3a**

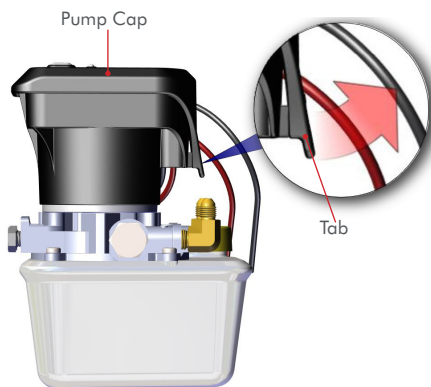

Figure 1

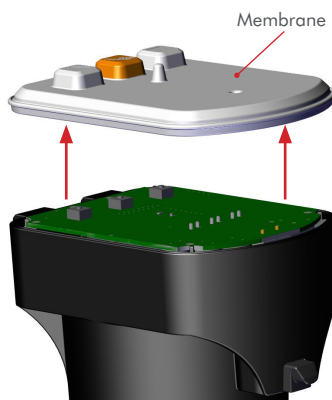

Figure 2

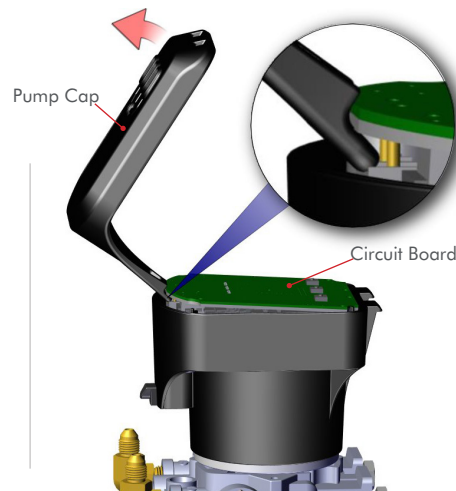

Figure 3

Installation:

STEP 1: Install the new **Circuit Board** in place of the old one. **FIG 1**

IMPORTANT: Make sure the **Desi Pak** is on top of the **Motor Assembly**. **FIG 1a**

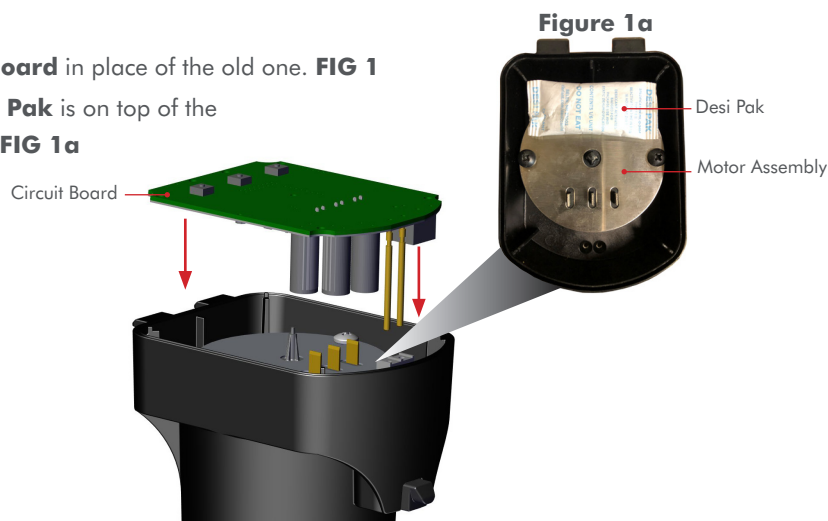

Figure 1

Need help? Contact our Technical Support Team at **1 + 813.689.9932 Option 2**

CM2 CIRCUIT BOARD REPLACEMENT INSTRUCTIONS

Installation (Continued):

STEP 2: Install the **Membrane**. Make sure it seats squarely in the **Motor Casing Groove**. **FIG 2**

STEP 3: Reinstall the **Pump Cap**. You may need to push up on the **Wire Harness** while pushing down on the **Cap**. **FIG. 3**

NOTE: If buttons stick, remove the **Pump Cap** and reinstall the **Membrane**.

STEP 4: Reconnect the **RED (+)** 12V wire to the battery or reinstall the Inline Fuse.

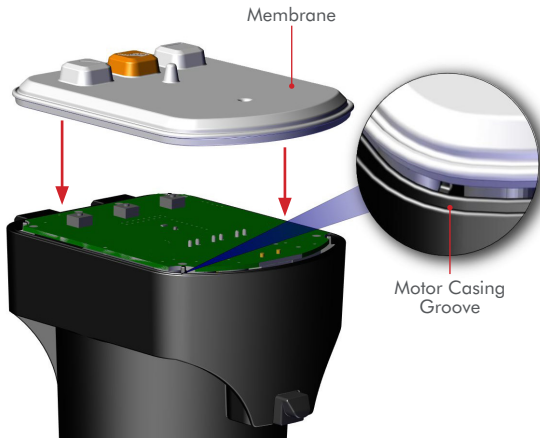

Figure 2

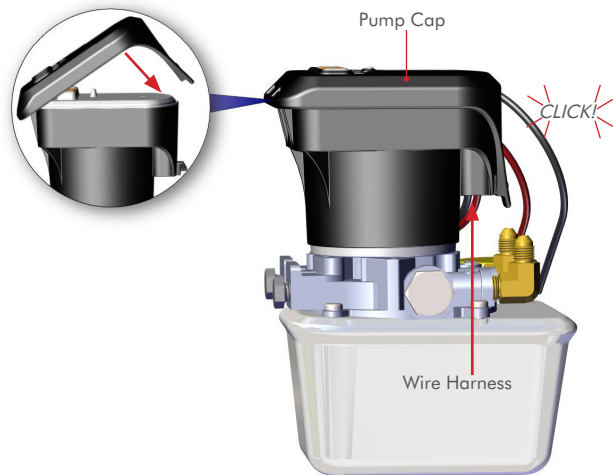

Figure 3

Programming Instructions:

New Circuit Boards come factory set as a single unit. For dual setups, pumps must be programmed as either a **"Port"** or **"Starboard"** unit. Follow the instructions below.

Press and hold the **PROGRAM** button for 6 seconds until the **LED** flashes **RED** and 2 chimes are heard followed by a single beep.

- **Starboard HPU:** Press and release the **UP** Button. **LED** will flash **RED** 1 time with a single beep. Press and release the **PROGRAM** button to save and exit. **LED** will flash **RED** 1 time with a single beep followed by 2 consecutive beeps.
- **Port HPU:** Press and release the **DOWN** button. **LED** will flash **RED** twice with 2 consecutive beeps. Press and release the **PROGRAM** button to save and exit. **LED** will flash **RED** 2 times with a double beep followed by 2 consecutive beeps.
- Programming may also be done via the C-Monster App.

IMPORTANT: When Programming a pump with new circuit board, connect it to the C-Monster app to check for a firmware update!

Pairing Instructions:

All remote accessories (Dash Switch, Foot Switches, and Key Fob) will need to be paired again after a new circuit board has been installed.

STEP 1: Press and hold the **PROGRAM** button on top of the unit for 3 seconds (**LED** will turn **GREEN**/HPU will beep).

STEP 2: Press the **UP** or **DOWN** button on controller for one second. When paired, the **GREEN LED** will turn off, then flash steadily (HPU will also beep).

IMPORTANT: The first time a remote is paired with a recently updated pump, it may perform a firmware update. Remote will blink for 1 minute. **DO NOT** interrupt power to pump or remote during this process. Blinking will stop when update is finished.



Need help? Contact our Technical Support Team at **1 + 813.689.9932 Option 2**