

INSTALLATION MANUAL

Power-Pole® Signature Series Shallow Water Anchor



Signature Series
SIGNATURE SERIES

Installation Instructions



CAUTION: Read this instruction manual carefully. Become familiar with the controls and know how to operate the Power-Pole shallow water anchor system safely.

US Pat No. 6,041,730



CONGRATULATIONS on your purchase of a Power-Pole Signature Series shallow water anchor featuring C-Monster Control System. It has been designed, engineered, and manufactured to provide the best possible performance and dependability for years of enjoyment.

Please read all installation instructions carefully. The information contained here describes the proper procedures for safely installing your Power-Pole shallow water anchor.



CAUTION:

Do not use the Power-Pole shallow water anchor as your primary anchorage. Never leave your boat unattended while anchored solely with the Power-Pole shallow water anchor.

Installation Tools & Hardware

Installation Tools

- 1/2" & 9/16" wrenches
- 1/2" & 9/16" sockets with ratchet
- Electric or battery operated drill
- 7/64", 9/64", 5/16", & 11/32" drill bits
- #2 Phillips-head bit or screwdriver
- Small slotted (flat-headed) screwdriver
- Heat gun
- 4' foot straight edge
- Marine grade sealant
- Fine point marker
- Tape measure
- Wire cutters
- Wire strippers
- Wire terminal crimpers
- Razor tubing cutter or utility razor blade
- Small funnel

Installation Hardware

- A** Qty(4) 5/16" x 3.5" all-thread transom mount bolts
- B** Qty(4) 5/16" neo-bond washers
- C** Qty(4) 5/16" fender washers
- D** Qty(4) 5/16" tall brass nuts
- E** Qty(2) 3/8" x 3/4" bolts
- F** Qty(2) 3/8" neo-bond washers
- G** Qty(2) #6 x 1/2" pan head screws
- H** Qty(4) #10 x 3/4" pan head screws
- i** Qty(1) rubber pump gasket
- J** Qty(2) ring connectors
- K** Qty(2) thru-hull bushings
- L** Qty(3) marine cable ties
- M** Qty(1) 5' black mesh tubing cover
- N** Qty(1) adhesive strip

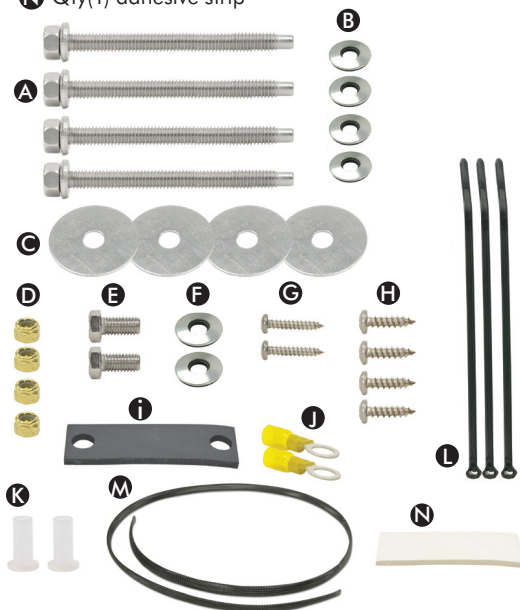

Step 1: Choose a Mounting Location

Transom mounting

VERTICAL POSITIONING

1. Place a straight edge on the bottom of the hull directly below and centered from the desired mounting location. The lowest point of the Power-Pole anchor must be at least 4" above this straight edge.

Note: If the Power-Pole anchor is mounted lower than the 4" minimum, the vessel may experience adverse handling effects. (See Figure #1)

CLEARANCE

1. If the vessel is equipped with trim tabs that measure 9" or less in length, the standard 4" minimum mounting height will be sufficient. If the trim tabs are larger than 9", the Power-Pole anchor will need to be mounted higher up on the transom to prevent interference.
2. While holding the Power-Pole anchor in place, turn and tilt the motor as far as possible toward the unit. With the motor turned toward the unit, manually move the anchor through its entire range of motion to verify clearance.
3. Once clearance has been verified on the exterior portion of the vessel, check for adequate space on the inside of the transom mounting area. Make sure that the bolts will not have any obstructions, and that you will have space to tighten the 5/16" tall brass nuts **D**.

Adapter plate mounting

1. If there is no suitable mounting location on the transom, your vessel will require an adapter plate. We offer adapter plates to accommodate a wide variety of applications. Please contact one of our authorized dealers or a member of our sales staff for an adapter plate recommendation: **(813) 689-9932 option 1**
2. All adapter plates are accompanied by installation instructions. Refer to the included instructions while installing the adapter plate as well as the Power-Pole anchor. Please contact our technical support team with any questions: **(813) 689-9932 option 2**

Figure 1

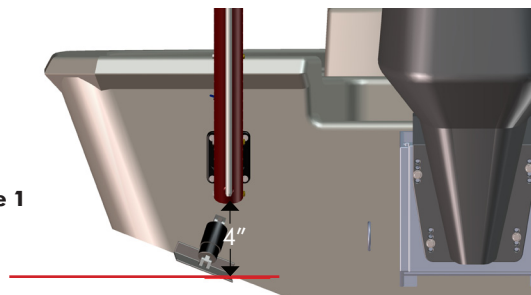

Step 2: Mounting the Power-Pole®

1. Once the mounting location has been selected, place the stern bracket against the transom, and mark the mounting holes with a fine point marker. Carefully drill pilot holes in each of the four marked locations with a 9/64" drill bit. Then, drill out each of the four pilot holes with a 5/16" drill bit.
2. Once all of the holes have been drilled, apply a liberal amount of marine grade sealant between the stern bracket and the hull, as well as around the 5/16" holes.
3. With a 1/2" wrench and 1/2" socket, fasten the stern bracket to the transom using (4) 5/16" x 3.5" all-thread transom mount bolts **A**, (4) 5/16" neo-bond washers **B**, (4) 5/16" fender washers **C**, and (4) 5/16" tall brass nuts **D**. The rubber backed neo-bond washers **B** will protect the powder coated surface of the stern bracket, and they must not be over tightened. (See Figure #2)

Figure 2

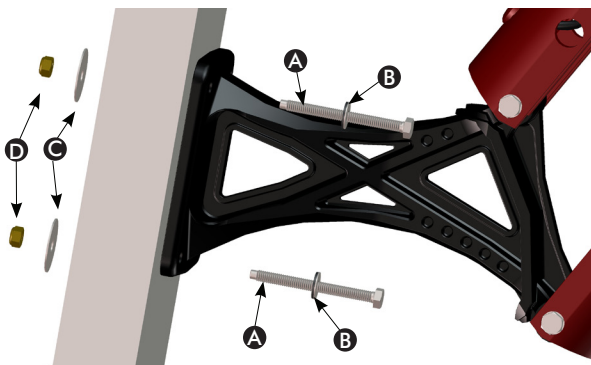

Step 4: Installing the HPU

1. Remove the fill cap on the HPU, and fill the reservoir to the "full" line with the supplied quart of Green Marine® biodegradable hydraulic fluid or an ISO 32 hydraulic fluid.

Using anything other than an ISO 32 hydraulic fluid, such as Green Marine, may cause damage to the HPU, and will void your warranty.



2. Place the HPU bracket in the predetermined area of the vessel, and inscribe the four mounting hole locations with a fine point marker.

Before drilling holes to mount the HPU mounting bracket, inspect the area beneath the mounting surface to insure that the drill bit will not cause any damage.

3. Using a 9/64" drill bit, carefully drill holes in the newly inscribed locations.
4. Fasten the bracket to the vessel using a #2 Phillips-head screwdriver and the (4) #10 x 3/4" pan head screws **H**.
5. Once the bracket is securely fastened, use a 9/16" wrench to attach the HPU to its bracket using the (2) 3/8" x 3/4" bolts **E**, (2) 3/8" neo-bond washers **F**, and (1) rubber pump gasket **I**. (See Figure #3 and 4)

Figure 3.1

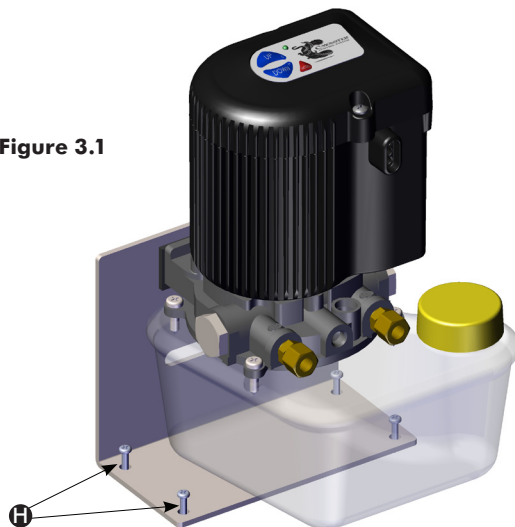

Step 3: Hydraulic Pump Unit (HPU)

Choose a mounting location

1. Locate a dry compartment in the vessel with ample space to accommodate the HPU. The footprint of the HPU is approximately 6.5"x 7".

Note: *Be sure to allow enough clearance surrounding the HPU such that the hydraulic tubing will not make a severe bend when exiting the compartment. Also, allow enough space to install the (2) 3/8" x 3/4" bolts **E** through the mounting bracket and into the HPU.*

Step 4: Continued

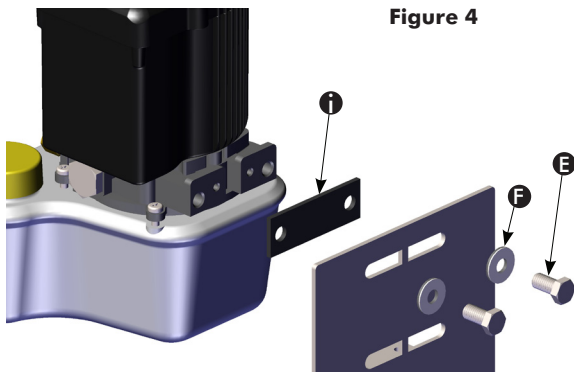

Figure 4

6. Unravel the red and black wires on the HPU. Route the red wire to a 12 volt positive source via a battery switch, and route the black wire to a 12 volt negative source via a common ground post.

Notice: This HPU will draw current (90 mA) from the battery source when not in use. JL Marine Systems, Inc. strongly recommends the use of a battery disconnect switch.

Note: Prior to cutting the excess wire, ensure that there is an adequate amount of slack such that they may be easily disconnected in the future.

7. Once the wires have been trimmed to length with wire cutters, install the (2) ring connectors (J) using wire strippers and wire terminal crimpers.
8. Heat the (2) ring connectors (J) with a heat gun until their respective jackets shrink completely and adhere to the wires.

WARNING: DO NOT CONNECT the red or black wire at this time. These wires will be connected once the hydraulic tubing is installed.

2. At this point, the hydraulic tubing may be routed in one of two ways. It may be routed either over the transom or through the transom using the (2) supplied thru-hull bushings (K). If the hydraulic tubing is not being installed through the transom, route the tubing to the HPU as per your preference, and proceed to Step E. If the hydraulic tubing is to be installed through the transom, holes will need to be drilled for the thru-hull bushings (K).

Note: When choosing a location for the holes, ensure that the tubing will form a natural curve when leaving the stern bracket, and that the transom holes will be above the water line.

3. First, drill pilot holes in the transom with a 9/64" drill bit for each of the (2) thru-hull bushings (K). Then, drill out both pilot holes with an 11/32" drill bit. Once the holes are drilled, insert the (2) thru-hull bushings (K), and route the tubing to the HPU. (See Figure #4)

Note: Be sure to allow an adequate amount of slack in the hydraulic tubing between the stern bracket and the point that the tubing enters the vessel. This will provide slack in the hydraulic lines to allow for full up and down operation.

4. The tubing is now ready to be attached to the HPU. Route the tubing according to your preference, and trim the excess using a razor tubing cutter. All cuts made in the tubing must be as straight as possible to ensure that the compression fittings do not leak.

Note: For ease of future maintenance, leave enough excess hydraulic tubing such that the HPU can be moved out of the compartment with the tubing still attached.

5. While taking note of their orientation, remove the blue and black dust caps from the hydraulic compression fittings on the HPU.
 6. Disassemble both of the compression fittings by removing their nuts and ferrules. With both the blue and black hydraulic tubing cut to length, feed each through a compression fitting nut as well as a compression fitting ferrule. (See Figure #5)
- Note:** The tubing needs to pass through the ferrule far enough such that there is approximately a 1/2" length of tubing exposed. (See Figure #5)

Step 5: Installing Hydraulic Tubing

1. Guide the blue and black hydraulic tubing through the black mesh tubing cover (M).

Note: The black mesh tubing (M) cover may need to be trimmed to length.

WARNING: Keep debris out of the hydraulic tubing. Use the red end caps provided at all times while routing the hydraulic tubing throughout the boat. Debris in the tubing will cause damage to the HPU.

Step 5: Continued

7. Insert the blue tubing into the compression fitting labeled UP (blue dust cap), and the black tubing into the fitting labeled DN (black dust cap). While holding the blue tubing fully inserted into its respective compression fitting base, begin threading the compression fitting nut onto the base. Repeat this step for the black tubing. (See Figure #6)

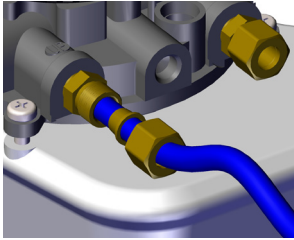

Figure 5

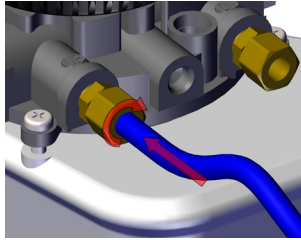

Figure 6

8. Tighten both compression fitting nuts with a 9/16" wrench while simultaneously holding their respective bases with a 1/2" wrench. (See Figure #7)

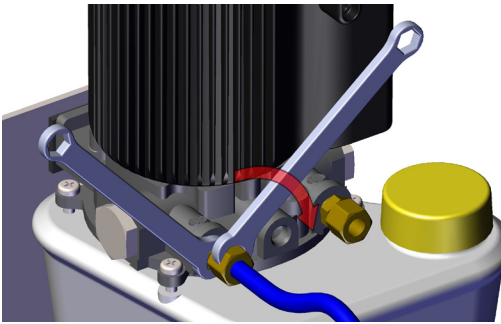

Figure 7

Warning: The nuts must be tightened down far enough such that none of the compression fitting's threads are visible; otherwise, hydraulic failure may occur. (See Figure #8)

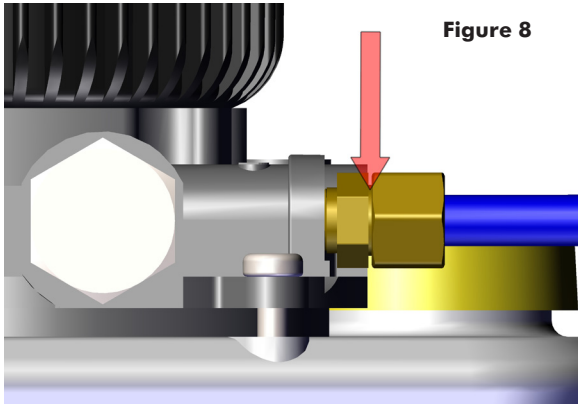
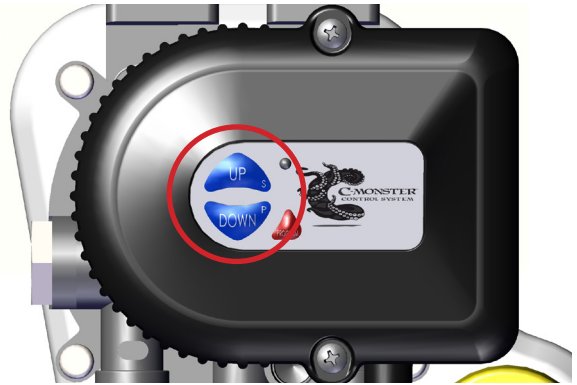

Figure 8

Step 6: Priming the HPU

1. Now connect the red and black wires from the HPU to their respective locations. **See Step 4.** Once both wires are securely fastened, the green LED on the HPU should flash indicating that the unit has power.
2. Use the "down" button on the HPU cover to cycle the Power-Pole anchor from the fully retracted position to the point where it makes contact with a solid surface. (See Figure #9)

Figure 9



3. Once the unit has reached the end of its range of motion, keep the "down" button depressed for 5 seconds in order to bleed all residual air from the hydraulic tubing. Next, retract the anchor with the "up" button. Once again, keep the button depressed for 5 seconds in order to bleed all residual air from the hydraulic tubing. Repeat this process three times in both directions or until satisfactory performance is achieved.
4. The HPU's hydraulic fluid level may need to be topped-off after the final priming has been completed.

Step 7: Pairing the Dash Switch and Remote Control

1. Locate the "program" button on the top of the pump unit, depress and hold it for 3 seconds until the LED steadily illuminates green in color. The pump unit is now ready to be paired with the switch. The HPU will remain in the pairing mode for 20 seconds. (See Figure #10)

Note: When dual Power-Pole shallow water anchors are installed, this procedure should be performed on BOTH pump units.

Step 7: Continued

Figure 10



Figure 11



2. Next, depress and release the button on the remote 1 time. The green LED on the pump unit will initially turn off, and then it will flash steadily indicating that the pairing has been completed. (See Figure #11)
3. The surface mount switch is now paired to the pump unit. Test its functionality by following the operating instructions to ensure that the pairing procedure was completed successfully.
4. Repeat the same programming procedure with the remote control. (See Figure #10)

Step 8: Programming the HPU/HPUs

In order to utilize the full potential of the Power-Pole shallow water anchor, the HPU/HPUs must be assigned as either a single, port side, or starboard side unit. Follow the "single unit" instructions when installing only one anchor, and use the "dual units" instructions when installing two anchors. The "dual units" instructions must also be used when installing a second unit at a later date.

Note: Assigning a single unit as either a port side or starboard side unit will cause adverse operating behavior.

SINGLE UNIT

1. Locate the "program" button on the top of the HPU, and depress and hold it for 6 seconds until the LED steadily illuminates red in color. The LED will initially illuminate green (after 3 seconds), but will change to red after 6 seconds, thus indicating that the unit is ready to be programmed. (See Figure #12)
2. Next, depress and hold both the "up" and the "down" buttons on the HPU simultaneously. The LED will flash red 3 times indicating that the programming has been completed successfully for single unit operation.

Step 8: Continued

Figure 12

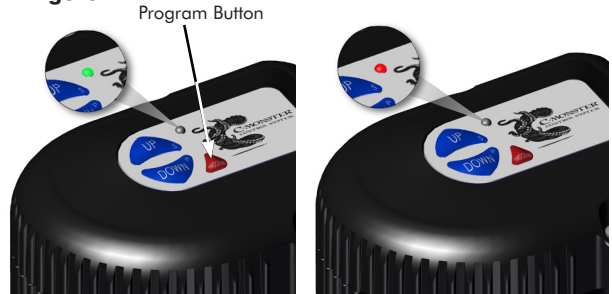

DUAL UNITS

1. Using the "up" and "down" buttons on both HPUs, determine which HPU controls the port side Power-Pole anchor and which one controls the starboard side. (See Figure #12)
2. With both HPUs identified, begin with the starboard side unit. Locate the "program" button on the top of the HPU, and depress and hold it for 6 seconds until the LED steadily illuminates red in color. The LED will initially illuminate green (after 3 seconds), but will change to red after 6 seconds, thus indicating that the unit is ready to be programmed.
3. Next, depress and hold the "up" button for the starboard side HPU. The LED will flash red 2 times indicating that the programming has been completed successfully, and the HPU has been assigned as the starboard side unit.
4. Repeat the programming procedure for the port side by depressing the "down" button on the second HPU. This time the LED will flash red 1 time indicating that the programming has been completed successfully, and the HPU has been assigned as the port side unit.



Step 9: Installing the Dash Switch

1. Locate a suitable area with a flat surface to mount the dash switch.
2. The dash switch must be installed with the slot in the base facing downward, which can be accomplished by using the supplied adhesive strip **(N)** or the (2) included #6 x 1/2" pan head screws **(G)**.
3. If using the (2) #6 x 1/2" pan head screws **(G)**, use a small slotted screwdriver to remove the dash switch cover plate. (See Figure #12)
4. While holding the dash switch base in the desired location, use a fine point marker to inscribe the intended mounting screw locations.

WARNING: Before drilling pilot holes for the dash switch mounting screws, inspect the area beneath the mounting surface in order to ensure that the drill bit will not cause any damage.

5. Using the 7/64" drill bit, carefully drill holes in the previously inscribed location.
6. Fasten the dash switch base to the vessel using a #2 Phillips-head screwdriver and the (2) #6 x 1/2" pan head screws **(G)**.
7. With the base installed, ensure that the rubber switch membrane is seated properly prior to installing the cover plate. (See Figure #13)



Figure 12

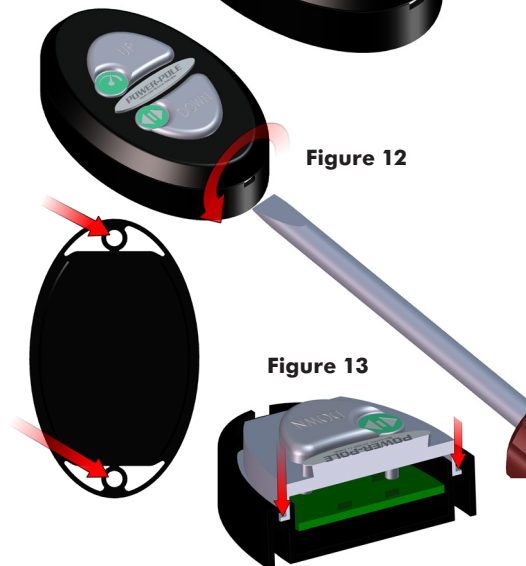

Figure 13

Need help? Contact our Technical Support Team at
813.689.9932 option 2



9208 Palm River Road, Suite 303, Tampa, Florida 33619
Phone 813-689-9932 Fax 813-689-8883

www.power-pole.com